



DIECI



40.14

40.17

ICARUS

PERFORMANCE		
Machine model	ICARUS 40.14	ICARUS 40.17
Maximum capacity	4000 kg (8818 lb)	4000 kg (8818 lb)
Maximum lifting height on wheels	13,20 m (43 ft)	16,70 m (55 ft)
Maximum horizontal extension on wheels	9,50 m (31 ft)	11,60 m (38 ft)
Fork swiveling angle	134°	134°
Pull-out force	5700 daN (12814 lbf)	5700 daN (12814 lbf)
Towing force	7300 daN (16411 lbf)	7300 daN (16411 lbf)
Maximum climb angle	40%	40%
Unladen weight	10900 kg (24030 lb)	12260 kg (27029 lb)
Max speed (referred to wheels with maximum permitted diameter)	35 km/h (21,7 mph)	35 km/h (21,7 mph)
BOOM		
Machine model	ICARUS 40.14	ICARUS 40.17
Lifting	12,3 s	14,1 s
Getting off the basket	8,4 s	10,2 s
Extension	21,4 s	21,4 s
Retraction	15,6 s	14,1 s
Forward swiveling	3,3 s	3,3 s
Reverse swiveling	2,1 s	2,1 s
ENGINE		
Machine model	ICARUS 40.14	ICARUS 40.17
Brand	FPT	FPT
Nominal power	93 kW (125 HP)	93 kW (125 HP)
@rpm	2200 rpm	2200 rpm
Operation	4-stroke	4-stroke
Injection	Mechanical direct	Mechanical direct
Number and arrangement of cylinders	4, Vertical in line	4, Vertical in line
Displacement	4485 cm ³ (274 in ³)	4485 cm ³ (274 in ³)
Consumption	230 g/kWh (378,35 lb/Hp h)	230 g/kWh (378,35 lb/Hp h)
@rpm	2200 rpm	2200 rpm
Emission standards	Stage IIIA/Tier 3	Stage IIIA/Tier 3
Cooling system	Liquid	Liquid
Intake	Turbo compressor after-cooler	Turbo compressor after-cooler
DIFFERENTIAL AXLES		
Machine model	ICARUS 40.14	ICARUS 40.17
Axles type	2 steering, with 4 planetary reduction gears	2 steering, with 4 planetary reduction gears
Type of steering	4 wheels / transversal / 2 wheels	4 wheels / transversal / 2 wheels
Front axle	Rigid (Levelling upon request)	Rigid (Levelling upon request)
Rear axle	Swinging	Swinging
Service braking	Oil bath with servo brake on front and rear axle with double hydraulic system	Oil bath with servo brake on front and rear axle with double hydraulic system
Parking braking	Negative actuation with electrical control	Negative actuation with electrical control
HYDRAULIC SYSTEM		
Machine model	ICARUS 40.14	ICARUS 40.17
Hydraulic pump type	Gear pump for power steering and movements	Gear pump for power steering and movements
Hydraulic pump capacity	130 L/min (34,3 gal/min)	130 L/min (34,3 gal/min)
Max. operating pressure	25,0 MPa (3626 psi)	25,0 MPa (3626 psi)
Distributor control	4in1 proportional Joystick	4in1 proportional Joystick
REFUELING		
Machine model	ICARUS 40.14	ICARUS 40.17
Hydraulic system (total)	174,0 L (45,97 gal)	174,0 L (45,97 gal)
Diesel tank	105,0 L (27,74 gal)	105,0 L (27,74 gal)
TRANSMISSION		
Machine model	ICARUS 40.14	ICARUS 40.17
Transmission type	Hydrostatic with variable flow pump	Hydrostatic with variable flow pump
Hydraulic motor	Hydrostatic with continuous automatic adjustment	Hydrostatic with continuous automatic adjustment
Reversal	Electro-Hydraulic	Electro-Hydraulic
Inching	With hydraulic pedal for controlled forward movement	With hydraulic pedal for controlled forward movement
Transmission gearbox	Servocontrolled 2-speed	Servocontrolled 2-speed
TIRES		
Machine model	ICARUS 40.14	ICARUS 40.17
Standard tires	400/70x20"	400/70x24"
Optional tires	400/70x24"; 18x22.5"	18x22.5"

DIMENSIONS

Machine model	ICARUS 40.14	ICARUS 40.17
A	390 mm (15,4 in)	390 mm (15,4 in)
B	1900 mm (74,8 in)	1970 mm (77,6 in)
C	2950 mm (116,1 in)	2950 mm (116,1 in)
D	1355 mm (53,3 in)	1355 mm (53,3 in)
F	4850 mm (190,9 in)	4900 mm (192,9 in)
G	6200 mm (244,1 in)	6275 mm (247 in)
H	2500 mm (98,4 in)	2550 mm (100,4 in)
I	940 mm (37 in)	940 mm (37 in)
L	1950 mm (76,8 in)	1950 mm (76,8 in)
M	2360 mm (92,9 in)	2360 mm (92,9 in)
N	3270 mm (128,7 in)	3270 mm (128,7 in)
O	4900 mm (192,9 in)	490 mm (19,3 in)
P	1700 mm (66,9 in)	1700 mm (66,9 in)
Q	4400 mm (173,2 in)	4400 mm (173,2 in)
S	1810 mm (71,3 in)	1837 mm (72,3 in)
T	106 mm (4,2 in)	163 mm (6,4 in)

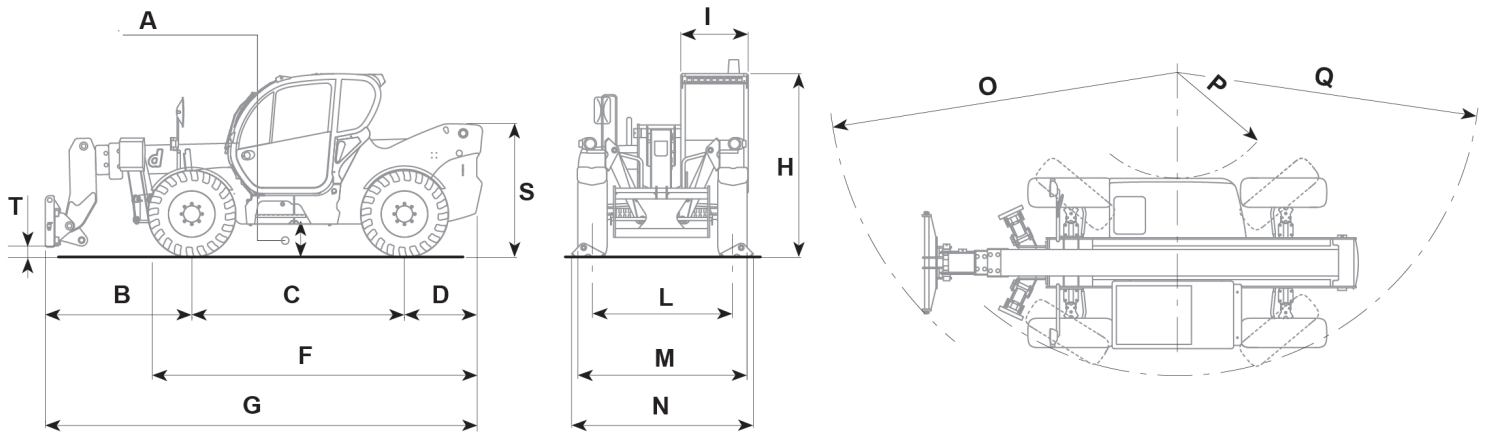

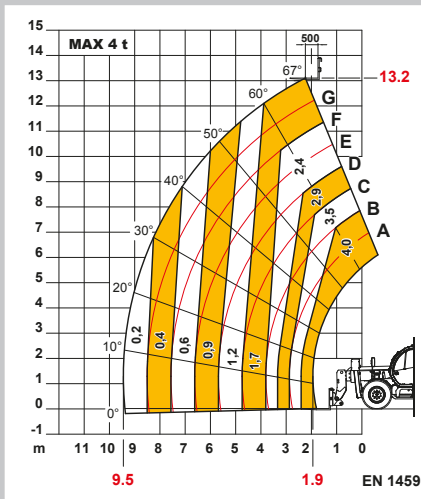

Icarus 40.14

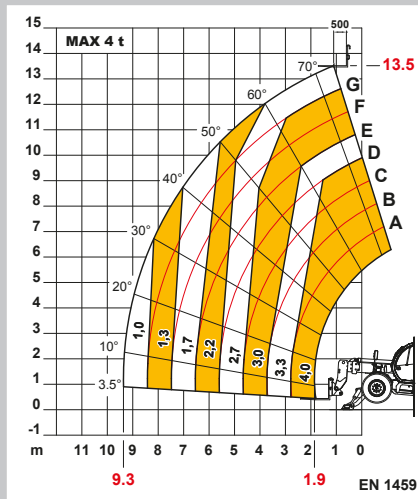

Icarus 40.14

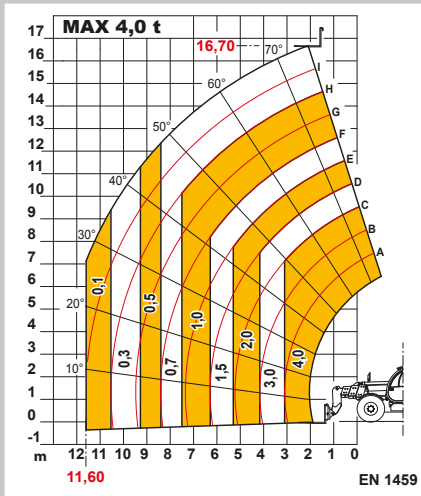

Icarus 40.17

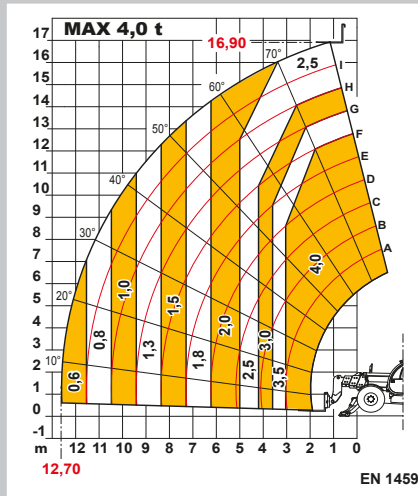

Icarus 40.17